

SPUTO AND LAMMERT ENGINEERING, LLC
STRUCTURAL ENGINEERS
10 SW 1ST AVENUE, GAINESVILLE, FL 32601
PHONE: 352-378-0448 FAX: 352-373-1331
E-MAIL: sputoandlammert@mindspring.com

PRODUCT EVALUATION REPORT

MANUFACTURER:

Crane Composites, Inc.
8015 Dixon Drive
Florence, KY 41042

SUBJECT:

Fiber reinforced plastic (FRP) roof panels

PRODUCT CATEGORY:

Structural Components: Roof Deck

PRODUCT DESCRIPTION:

Duralite High Strength R-Panel

CODE CRITERIA:

Florida Building Code 2007:

Chapter 15: Roof Assemblies and Rooftop Structures

1504.3

Chapter 26: Plastic

2606

2609

REFERENCE STANDARDS:

ASTM D1929	1996(2000)
ASTM D635	2003
ASTM E84	2004
UL580	1994

BASIS OF EVALUATION:

1. Structural load carrying capacity is based on rational analysis using test results.
 - a. Since there is no approved structural design standard for fiberglass reinforced plastic (FRP) roof panels listed in the Florida Building Code, the common

industry standard of applying a factor of safety of 2.0 against strength as determined from UL580 testing was applied. Maximum sustained pressure during testing was 83.1 psf. Applying a factor of safety of 2.0 results in an allowable design pressure of 41.5 psf.

2. Fire resistance is based on testing to standards.
 - a. ASTM D1929 – 488° C Spontaneous-Ignition or Self-ignition Temperature per test (greater than 343° C required)
 - b. ASTM D635 – Class CC2 classification per test (acceptable classification)
 - c. ASTM E84 – 250 Smoke Developed Index per test (not greater than 450 required)

LIMITATIONS AND CONDITIONS OF USE FOR NON-HVHZ:

1. Approved for use in HVHZ: No
2. Approved for use outside HVHZ: Yes
3. Impact Resistant: No
4. Design Pressure: +41.5/-41.5
5. Other:
 - A. Panels to be installed over steel framing in accordance installation instructions, double span (or more) condition.
 - B. Not for use as a shear diaphragm.
 - C. Design engineer must evaluate the panel for web crippling and fastener pullout/pullover.
 - D. Minimum installed roof slope is 0.5/12.
 - E. Impact resistance is not evaluated.
6. Limit panel area according to FBC Table 2609.4

TECHNICAL DOCUMENTATION SUPPORTING COMPLIANCE STATEMENT:

1. UL580 Uplift Resistance Testing by Farabaugh Engineering and Testing, May 2010
2. Installation drawings.
3. ASTM D1929, E84, D635 test results.

CODE COMPLIANCE CERTIFICATION

As product evaluator, the undersigned certifies that the listed products are in compliance with the requirements of the 2007 Florida Building Code.

Sincerely,

SPUTO AND LAMMERT ENGINEERING, LLC



Thomas Sputo, Ph.D., P.E.
Florida PE 39142

DATE OF REPORT: 26 May 2010



ASTM D635-06
Rate of Burning and/or Extent and Time of Burning of Plastics in a Horizontal Position

Client: Crane Composites
8015 Dixon Dr
Florence, KY 41042

Report No.: 100054347

Received Date: February 2010 (The specimens were received in good condition.)

Test Date: March 18, 2010

Report Date: March 30, 2010

Sample Description: 8oz 162DLW Panel

Sample Dimensions: 13mm x 125mm. x 1.8mm

Sample Preparation: Tested as received.

Environmental Conditions: 72°F and 35% R.H.

Sample Conditioning: 73±5°F and 50±5% R.H.

HB Category Designation

The behavior of specimens shall be classified HB (HB = horizontal burning) if,
a.) There is no visible signs of combustion after the source is removed, or **b.)** The flame front does not pass the 25 mm reference mark, or **c.)** The flame front passes the 25 mm reference mark but does not reach the 100 mm reference mark, or **d.)** The flame front reaches the 100 mm reference mark and the linear burning rate does not exceed 40 mm/min for specimens having a thickness between 3 and 13 mm or 75 mm/min for specimens having a thickness less than 3 mm.

International Building Code CC1 & CC2 Criteria

Class CC1: Plastic materials that have a burning extent of 25 mm or less where tested at a nominal thickness of 0.060 in. (1.5 mm), or in the thickness intended for use, in accordance with this test method.

Class CC2: Plastic materials that have a burning rate of 2.5 in. per minute (63.6 mm/min.) or less where tested at a nominal thickness of 0.060 in. (1.5 mm), or in the thickness intended for use, in accordance with this test method.

Summary of Test Method

A bar of the material to be tested is supported horizontally at one end. The free end is exposed to a specified methane gas flame for 30s. Elapsed time (t) and Burned length (L) are measured and reported if the specimen burns between 25 mm and 100 mm. An average burning rate is reported for a material if it burns to the 100 mm mark from the ignited end. If 3 specimens burn to the 100 mm mark, the test is terminated and the average burning rate is reported. If the flames do not reach the 100 mm mark, 10 specimens are tested and the burn rate is not reported.

"This standard should be used to measure and describe the properties of materials, products, or assemblies in response to heat and flame under controlled laboratory conditions and should not be used to describe or appraise the fire hazard or fire risk of materials, products, or assemblies under actual fire conditions. However, results of this test may be used as elements of a fire risk assessment which takes into account all of the factors which are pertinent to an assessment of the fire hazard of a particular end use."

TEST RESULTS

Specimen	Did Flame Reach 25mm (Y/N)	Did Flame Reach 100mm (Y/N)	Elapsed Time (t) (sec)	Burned Length (L) (mm)	Burning Rate (mm/min)
1	Yes	Yes	203	75	19.58
2	Yes	Yes	162	75	27.78
3	Yes	Yes	206	75	21.87
Average			190	75	23.08

Note:

Test series was restricted to 3 specimens instead of 10 for reasons stated in Section 9.8 of the ASTM D635-06 standard which reads, "Repeat the test procedure until 3 specimens have burned to or beyond the 100mm reference mark, or 10 specimens have been tested."

Conclusion

This specimen meets the HB classification requirements and in accordance with Section X2 of ASTM D635 for International Building Code Section 2606.4 referenced materials, the material tested also meets Class CC2 requirements.

This report is for the exclusive use of Intertek's Client and is provided pursuant to the agreement between Intertek and its Client. Intertek's responsibility and liability are limited to the terms and conditions of the agreement. Intertek assumes no liability to any party, other than to the Client in accordance with the agreement, for any loss, expense or damage occasioned by the use of this report. Only the Client is authorized to copy or distribute this report and then only in its entirety. Any use of the Intertek name or one of its marks for the sale or advertisement of the tested material, product or service must first be approved in writing by Intertek. The observations and test results in this report are relevant only to the sample tested. This report by itself does not imply that the material, product, or service is or has ever been under an Intertek certification program.

This report consists of three pages.



Mark Crawford
Chemist

March 30, 2010

Reviewed and approved:



Rhonda Byrne
Operations Manager

March 30, 2010

**ASTM D1929-96 (reapproved 2001)
Standard Test Method for Determining
Ignition Properties of Plastics**

8.0 oz DLW (Duralite High Strength) panel

Project No. 100054347

Report No. 100054347WI3-002

May 3, 2010

Prepared for:

Michelle Smith
Crane Composites Inc.
8015 Dixon Drive
Florence, KY 41042

ABSTRACT

Specimens submitted by Michelle Smith of Crane Composites Inc. and identified as "8.0 oz DLW (Duralite High Strength) panel" were tested in accordance with the ASTM D 1929-96 (2001) Standard Test Method for Determining Ignition Temperature of Plastics with the following results:

Flash-Ignition Temperature: 378°C (712.4°F) Flaming

Spontaneous-Ignition Temperature: 488°C (910.4°F) Flaming

This report contains a total of 10 pages.

This report is for the exclusive use of Intertek's Client and is provided pursuant to the agreement between Intertek and its Client. Intertek's responsibility and liability are limited to the terms and conditions of the agreement. Intertek assumes no liability to any party, other than to the Client in accordance with the agreement, for any loss, expense or damage occasioned by the use of this report. Only the Client is authorized to copy or distribute this report and then only in its entirety. Any use of the Intertek name or one of its marks for the sale or advertisement of the tested material, product or service must first be approved in writing by Intertek. The observations and test results in this report are relevant only to the sample tested. This report by itself does not imply that the material, product, or service is or has ever been under an Intertek certification program.

"These tests results relate only to the behavior of test specimens under the particular conditions of the test. They are not intended to be used, and shall not be used, to assess the potential fire hazard of a material in use." (ASTM International D 1929 – 96 Reapproved 2001, Section 9.1.10)



Bryan Bowman
Chemist

May 3, 2010

Reviewed and approved:



Rhonda Byrne
Operations Manager

May 4, 2010

INTRODUCTION

This test standard outlines a laboratory determination of the spontaneous ignition and flash ignition temperatures of plastics using an electric hot air furnace defined in ASTM International Standard Test Method for Determining Ignition Temperature of Plastics Designation: D 1929-69 (Reapproved 2001).

“This standard is used to measure and describe the response of materials, products, or assemblies to heat and flame under controlled laboratory conditions, but does not by itself incorporate all factors required for fire hazards or fire risk assessment of materials, products, or assemblies under actual fire conditions.” (ASTM International D 1929 – 96 Reapproved 2001, Section 1.3)

“Tests made under conditions herein prescribes can be of considerable value in comparing the relative ignition characteristics of different materials. Values obtained represent the lowest ambient are temperature that will cause ignition of the material under the conditions of the test. Test values are expected to rank materials according to ignition susceptibility under actual use conditions.” (ASTM International D 1929 – 96 Reapproved 2001, Section 4.1)

“This test is not intended to be the sole criterion for fire hazard. In addition to ignition temperature, fire hazards include other factors such as burning rate or flame spread, intensity of burning, fuel contribution, products of combustion and others.” (ASTM International D 1929 – 96 Reapproved 2001, Section 4.2)

DEFINITIONS

Flash-Ignition Temperature (FIT) – *“The minimum temperature at which, under specific test conditions, sufficient flammable gases are emitted to ignite momentarily upon application of a small external pilot flame.”* (ASTM International D 1929 – 96 Reapproved 2001, Section 3.2.1)

Glowing Combustion – *“Combustion of material in the solid phase without flame but with emission of light from the combustion zone, caused by slow decomposition and carbonization at various points in the specimen, without general ignition occurring.”* (ASTM International D 1929 – 96 Reapproved 2001, Section 3.2.2)

Spontaneous-Ignition or self-ignition Temperature (SIT) – *“The minimum temperature at which the self-heating properties of the specimen lead to ignition or ignition occurs of itself, under specific test conditions, in the absences of any additional flame ignition source.”* (ASTM International D 1929 – 96 Reapproved 2001, Section 3.2.3)

TEST PROCEDURE

Apparatus and Setup:

The test apparatus consisted primarily of an insulated electric hot-air ignition furnace (#19019) controlled by a variable transformer and specimen holder. The hot air ignition furnace consisted of an inner ceramic tube with an inside diameter of 76 mm and length of 230mm and a thickness of approximately 3mm. positioned 20mm above the bottom of the furnace by spacers. The outer furnace ceramic tube consisted of a vertical tube with an inside diameter of 100mm and length of 230mm placed on the furnace floor. The air source consisted of a metered (Top Track #000872), clean air supply circulated in the space between the two tubes and entered the inner furnace tube at the top. The top was covered with a heat-resistant material with a 25mm diameter opening. The specimen support and holder consisted of a specimen pan in a metal container of approximately 0.5mm thickness measuring 40 +/- 2mm in diameter and 15 +/- 2mm in depth, and a ring of 2.0 mm stainless steel welding wire supported by wire of the same diameter. Pilot light tubing was located immediately above the opening attached to a propane gas supply of CP quality. All thermocouples were K type thermocouple attached to an Omega Data acquisition system model #OMB DAQ 56 (#1153).

The air velocity was set to 25 mm/s +/- 10% using the flow meter that measures in SCFM and adjusting for the temperature of the Furnace T_3 using the equation $Q_v = 6.62 \times 293/T$ where T = Temperature in $^{\circ}K$ at T_2 and Q_v is the air flow rate in L/min. The air flow rate Q_v in L/min is then converted into SCFM by multiplying by 0.0353. The bottom of the specimen pan was located 185 +/- 5mm down from the top of the inner furnace tube.

For the Flash Ignition Temperature testing, the pilot flame was adjusted to 20 +/- 2mm in length and centered above the opening of the cover. No pilot light is used for the Spontaneous Ignition Temperature testing.

The temperatures were collected using a Personal Daq View XL onto a Microsoft XL spreadsheet. T_1 was located as close as possible to the center of the upper surface of the specimen and attached to the support rod. T_2 gives an indication of the air traveling past the specimen. The T_2 thermocouple was located 10 +/- 2mm below the center of the specimen pan. The thermocouple was attached to the specimen support rod. T_3 measured the temperature of the furnace heating coil and was used as a reference temperature. A fourth K type thermocouple was placed 185mm down from the top of the inner furnace tube during the equilibration of the furnace to be used as a reference starting temperature to represent the expected T_2 temperature. This thermocouple was used as a reference and removed prior to starting the testing.

Four sample lengths of 20mm +/- 2 mm were cut by the client to make to make a mass of 3.0 +/- 0.2g to make one specimen using a Mettler Toledo balance (#19767).

Flash Ignition Temperature (FIT):

The electric current supplied to the heating coils by means of a variable transformer was adjusted by reference to the furnace temperature T_3 until the air temperature T_2 remains constant at the desired temperature, and not changed during the testing. If no starting temperature is given, the starting furnace temperature will be 400°C . The specimen was placed in the pan assuring that T_1 and T_2 thermocouple wires were in the correct location. The pilot light was started. The specimen was lowered into the furnace and furnace opening was closed. The timer and data collection system was started.

The furnace opening was watched for the evidence of a flash or mild explosion of combustible gases that may be followed by the burning of the specimen. Flaming or glowing combustion can also be observed by the rapid rise in temperature T_1 as compared with T_2 . The temperature of the furnace T_3 was increased if ignition had not occurred by 50°C . The temperature was decreased if ignition had occurred (the standard stated 50°C). The temperature was lowered by 10°C from the lowest temperature range at which ignition occurred. The flash ignition temperature was recorded as the lowest air temperature, at which the flash is observed during the 10 minute period.

Spontaneous Ignition Temperature (SIT):

The test followed the same procedure as the flash ignition temperature described above but without the pilot flame. The ignition will be evident by flaming or glowing combustion of the specimen. It may be difficult with some material, to detect spontaneous ignition visually when burning is by glowing combustion rather than flaming. In such a case, a rapid rise in T_1 compared to T_2 accompanied by visual observation is the more reliable reference. The lowest air temperature T_2 at which the specimen burned during the 10 minute period was the spontaneous ignition temperature.

TEST SPECIMENS

Specimen I.D.: MID10030880813-001

Date received: April 2010 (This specimen was received in good condition.)

Date tested: 4/30/2010

Sample Form: Composite sheet

Description: 8.0 oz 162DLW (Duralite High Strength)

Environmental Conditions: $23 \pm 2^{\circ}\text{C}$ and $50 \pm 5\%$ relative humidity for not less than 40 hours prior to the testing.

This Test Witnessed by: None

TEST RESULTS & OBSERVATIONS

Test Method:		Standard Test Method for Determining Ignition Temperature of Plastics			
Designation of the Material:		Designation: D 1929 - 96 (Reapproved 2001)			
Form of Material:		8.0 oz DLW (Duralite High Strength) panel			
Flash Ignition Temperature					
Specimen	Mass (g)	Target Furnace Temp. T3	Combustion was Flaming or Glowing	Ignition Temperature	Observations
1	3.0	400	Flaming	388	White smoke at 4:30 minutes. At 5:54 minutes orange flames with black smoke, and some black soot.
2	2.9	350	None	None	White smoke at 4:24 minutes. No Ignition.
3	3.2	390	Flaming	378	White smoke at 4:00 minutes. Orange flame with black smoke and some black soot.
4	3.2	380	None	None	White smoke at 5:50. No Ignition.

Test Method:		Standard Test Method for Determining Ignition Temperature of Plastics			
Designation of the Material:		Designation: D 1929 - 96 (Reapproved 2001)			
Form of Material:		8.0 oz DLW (Duralite High Strength) panel			
Spontaneous Ignition Temperature					
Specimen	Mass (g)	Target Furnace Temp. T3	Combustion was Flaming or Glowing	Ignition Temperature	Observations
5	3.2	440	None	None	White smoke at 2:05 minutes. No ignition.
6	2.8	490	Flaming	492	White smoke at 1:30 minutes. Ignition with mild explosion. Orange flames and black smoke.
7	3.2	480	Flaming	488	White smoke at 1:30 minutes. Ignition with mild explosion. Orange flames with black smoke and black soot.
8	2.8	470	None	None	White smoke at 1:38 minutes. No ignition.

CONCLUSIONS

A white smoke occurred before ignition. Ignition occurred with orange flames, and black smoke with some black soot.

The flash ignition temperature is the lowest air temperature at which a flash is observed, during the 10 minute period. The spontaneous ignition temperature is the lowest air temperature at which the specimen burns, during the 10 minute period. The flash-ignition temperature of this material was determined to be 378°C (712.4°F) and the spontaneous ignition temperature was determined to be 488°C (910.4°F).

APPENDIX

Flash Ignition Temperature of Plastics D 1929 -96
Specimen 3

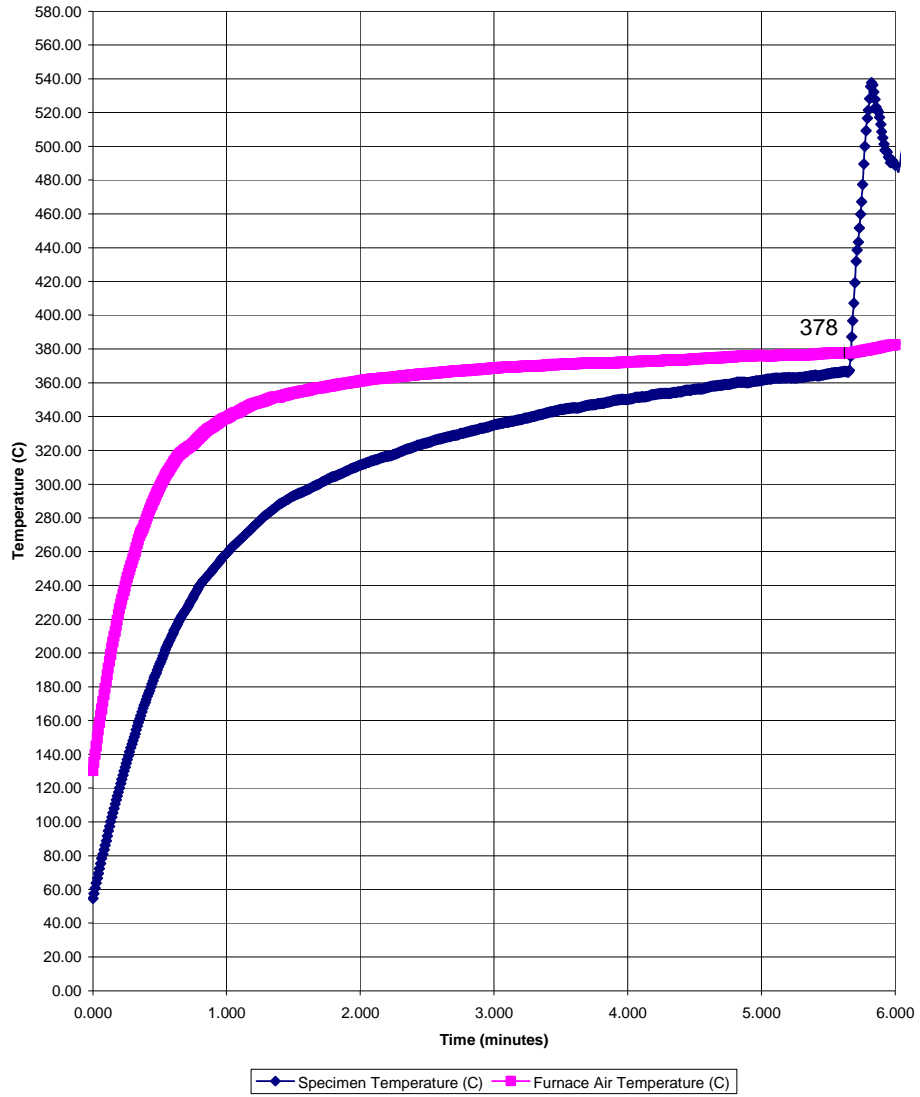

Spontaneous Ignition Temperature of Plastics D 1929 -96
Specimen 7

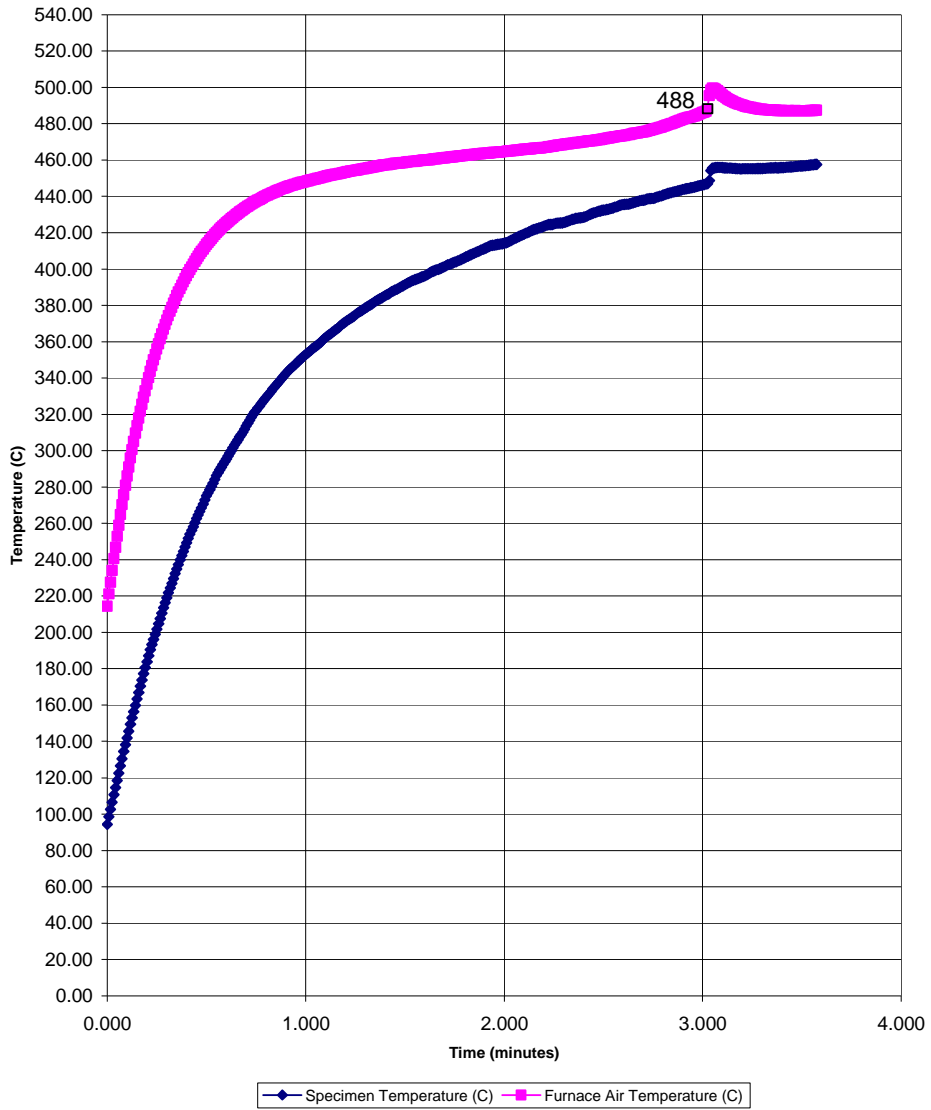

TEST REPORT



Intertek

REPORT NUMBER: 100054347SAT-003 Rev. 1
ORIGINAL ISSUE DATE: 3/31/2010
REVISED DATE: 4/9/10

EVALUATION CENTER
Intertek Testing Services NA Inc.
16015 Shady Falls Road
Elmendorf, TX 78112

RENDERED TO

Crane Composites, Inc.
8015 Dixon Drive
Florence, KY 41042

Report of Testing 8oz 162DLW (Duralite High Strength) Panel for compliance with the applicable requirements of the following criteria: ASTM E84-10 TEST FOR SURFACE BURNING CHARACTERISTICS OF BUILDING MATERIALS (UL 723, UBC 8-1, NFPA 255)

ABSTRACT

Test Material:	8oz 162DLW (Duralite High Strength) Panel	
Test Standard:	ASTM E84-10 TEST FOR SURFACE BURNING CHARACTERISTICS OF BUILDING MATERIALS (UL 723, UBC 8-1, NFPA 255)	
Test Date:	3/31/2010	
Test Sponsor:	Crane Composites	
Test Results:	FLAME SPREAD INDEX	205
	SMOKE DEVELOPED INDEX	250

This report is for the exclusive use of Intertek's Client and is provided pursuant to the agreement between Intertek and its Client. Intertek's responsibility and liability are limited to the terms and conditions of the agreement. Intertek assumes no liability to any party, other than to the Client in accordance with the agreement, for any loss, expense or damage occasioned by the use of the report. Only the Client is authorized to copy or distribute this report and then only in its entirety. Any use of Intertek name or one of its marks for the sale or advertisement of the tested material, product or service must first be approved in writing by Intertek. The observations and test results in this report are relevant only to the sample tested. This report by itself does not imply that the material, product, or service is or has ever been under an Intertek certification program.



Teodoro Alvarado, Jr.
Tunnel Operator

Date: April 9, 2010

Reviewed and Approved:



Servando Romo
Project Manager

Date: April 9, 2010

I. INTRODUCTION

This report describes the results of the ASTM E84-10 TEST FOR SURFACE BURNING CHARACTERISTICS OF BUILDING MATERIALS a method for determining the comparative surface burning behavior of building materials. This test is applicable to exposed surfaces, such as ceilings or walls, provided that the material or assembly of materials, by its own structural quality or the manner in which it is tested and intended for use, is capable of supporting itself in position or being supported during the test period.

The purpose of the method is to determine the relative burning behavior of the material by observing the flame spread along the specimen. Flame spread and smoke density developed are reported, however, there is not necessarily a relationship between these two measurements.

“The use of supporting materials on the underside of the test specimen may lower the flame spread index from that which might be obtained if the specimen could be tested without such support... This method may not be appropriate for obtaining comparative surface burning behavior of some cellular plastic materials... Testing of materials that melt, drip, or delaminate to such a degree that the continuity of the flame front is destroyed, results in low flame spread indices that do not relate directly to indices obtained by testing materials that remain in place.”

This test method is also published under the following designations:

NFPA 255
UL 723
UBC 8-1

This standard should be used to measure and describe the properties of materials, products, or assemblies in response to heat and flame under controlled laboratory conditions and should not be used to describe or appraise the fire hazard or fire risk of materials, products, or assemblies under actual fire conditions. However, results of this test may be used as elements of a fire risk assessment which takes into account all of the factors which are pertinent to an assessment of the fire hazard of a particular end use.

II. PURPOSE

The ASTM E84-10 (25 foot tunnel) test method is intended to compare the surface flame spread and smoke developed measurements to those obtained from tests of mineral fiber cement board and select grade red oak flooring. The test specimen surface (18 inches wide and 24 feet long) is exposed to a flaming fire exposure during the 10 minute test duration, while flame spread over its surface and density of the resulting smoke are measured and recorded. Test results are presented as the computed comparisons to the standard calibration materials.

The furnace is considered under calibration when a 10 minute test of red oak decking will pass flame out the end of the tunnel in five minutes, 30 seconds, plus or minus 15 seconds. Mineral fiber cement board forms the zero point for both flame spread and smoke developed indexes, while the red oak flooring smoke developed index is set as 100.

III. DESCRIPTION OF TEST SPECIMENS

Specimen Identification:	8oz 162DLW (Duralite High Strength) Panel
Date Received:	3/3/2010
Date Prepared:	3/3/2010
Conditioning (73°F & 50% R.H.):	28 days
Specimen Width (in):	24
Specimen Length (ft):	24
Specimen Thickness (in):	0.04
Material Weight:	N/A
Total Specimen Weight (lbs):	24
Adhesive or coating application rate:	N/A

Mounting Method:

The specimen was Self-supporting.

Specimen Description:

The specimen was described by the client as the “8oz 162DLW (Duralite High Strength) Panel”. The specimen consisted of (3) 8 foot long x 2 foot wide x 0.04-in thick panels. The product was received by our personnel in good condition.

IV. TEST PROCEDURE

The tests were conducted in accordance with the procedures outlined in the American Society for Testing and Materials ASTM E84-10. The self-supporting specimens were placed directly on the tunnel ledges. As required by the standard, on or more layers of 0.25 inch thick reinforced concrete board was placed on top of the test sample between the sample and the tunnel lid. After the tests, the samples were removed from the tunnel, examined and disposed of.

The test was conducted on 3/31/2010



V. TEST RESULTS & OBSERVATIONS

The test results, computed on the basis of observed flame front advance and electronic smoke density measurements are presented in the following table.

While no longer a part of this standard test method, the Fuel Contributed Value has been computed, and may be found on the computer printout sheet in the Appendix.

Test Specimen	Flame Spread Index	Smoke Developed Index
Mineral Fiber Cement Board	0	0
Red Oak Flooring		100
8oz 162DLW (Duralite High Strength) Panel	205	250

The data sheets are included in Appendix A. These sheets are actual print-outs of the computerized data system which monitors the tunnel furnace, and contain all calibration and specimen data needed to calculate the test results.

VI. OBSERVATIONS

During the test, the specimen was observed to behave in the following manner: The sample ignited at 0:30 (min:sec). The flames reached the end of the tunnel at 1:36 (min:sec). The test continued for the 10:00 duration.

After the test, the specimen was observed to be damaged as follows: The specimen was charred from 0-ft. – 24-ft.

APPENDIX
ASTM E84-10
DATA SHEETS

Client: CRANE COMPOSITES, INC.

Date: 3/31/2010

Project Number: 100054347SAT-003

Test Number: 1

Operator: TA/MP

Specimen Info: "8oz 162 DLW (DURALITE HIGH STRENGTH) PANEL". THE
SPECIMEN WAS SELF-SUPPORTING.

TEST RESULTS

FLAMESPREAD INDEX: 205

SMOKE DEVELOPED INDEX: 250

SPECIMEN DATA . . .

Time to Ignition (sec): 30
Time to Max FS (sec): 97
Maximum FS (feet): 19.6
Time to 980 F (sec): 162
Time to End of Tunnel (sec): 97
Max Temperature (F): 1111
Time to Max Temperature (sec): 215
Total Fuel Burned (cubic feet): 48.70

FS*Time Area (ft*min): 171.3
Smoke Area (%A*min): 271.5
Unrounded FSI: 206.5

CALIBRATION DATA . . .

Time to Ignition of Last Red Oak (Sec): 38.0
Red Oak Smoke Area (%A*min): 108.2

FLAME SPREAD (ft)

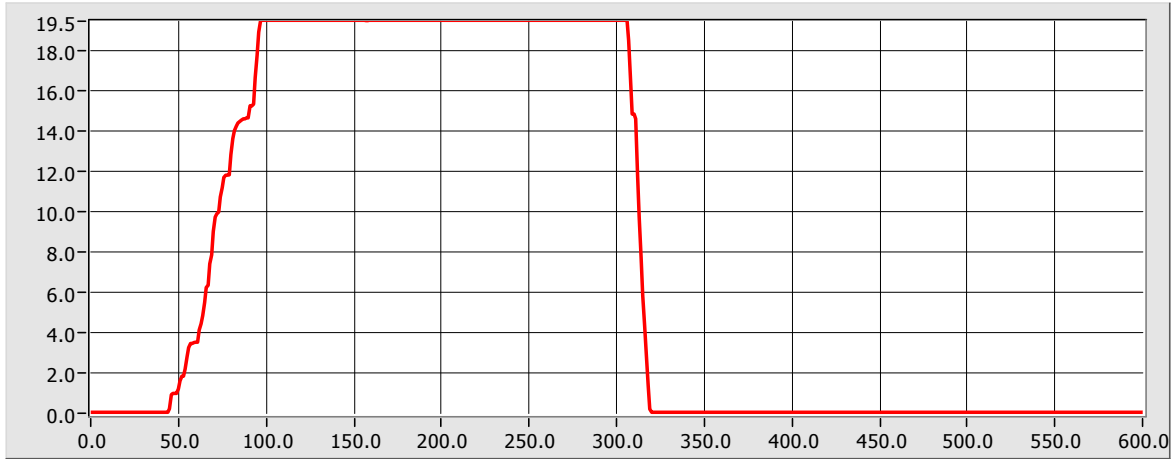

Smoke (%A)

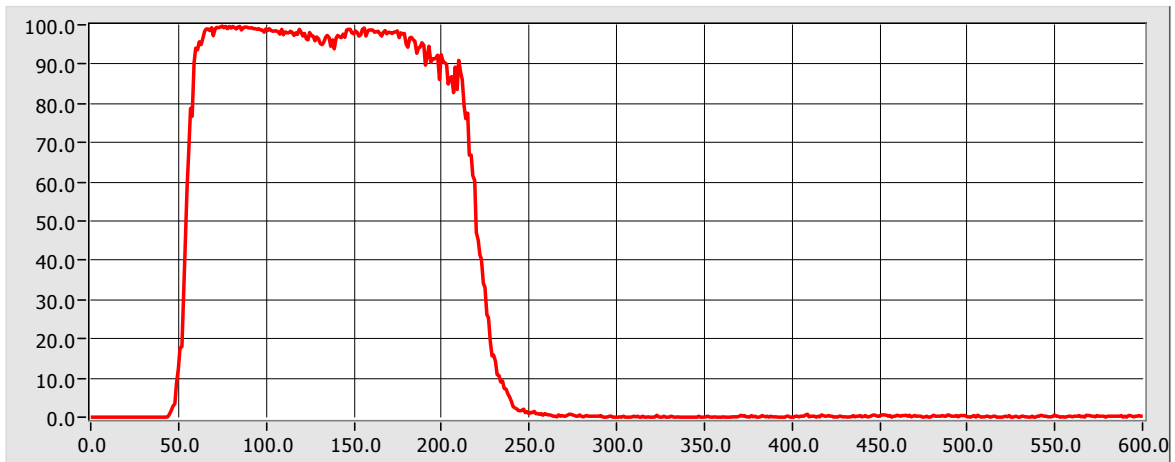

Temperature (°F)

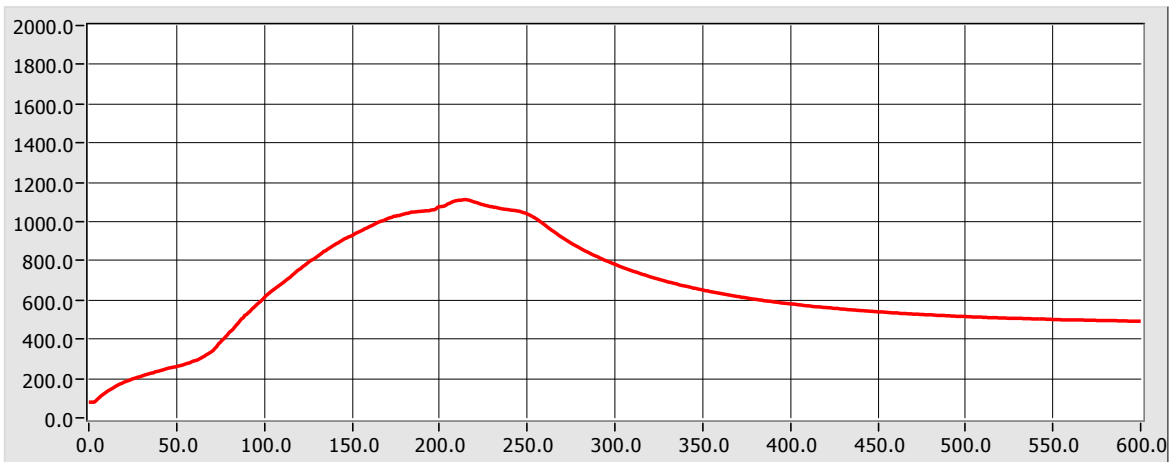

Time (sec)

600

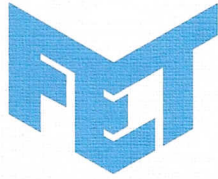

Farabaugh Engineering and Testing Inc.

Project No. T214-10

Report Date: May 10, 2010

No. Pages: 7 (inclusive)

UL 580 UPLIFT RESISTANCE TESTING

DURALITE HIGH STRENGTH R-PANEL

FOR

CRANE COMPOSITES
8015 DIXON DRIVE
FLORENCE, KY 41042

Report Prepared By:



Patrick J. Farabaugh, PE

Reviewed and Approved By:

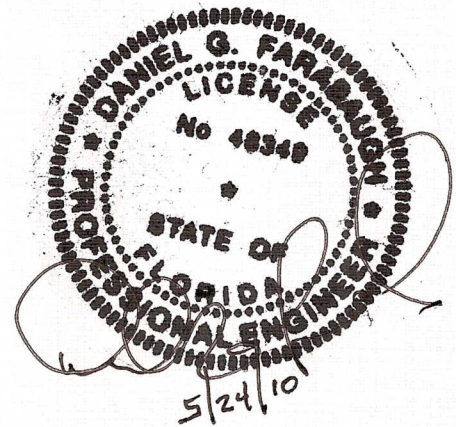
Daniel G. Farabaugh, PE

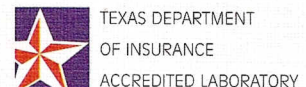

DANIEL G. FARABAUGH, P.E.
255 Saunders Station Rd.
Trafford, PA 15085
(412) 373-9238



Project No. T214-10

Purpose

This test method covers the evaluation of uplift resistance of roof assemblies per UL 580-94, rev. 1998 and as provided herein.

Test Specimen

Manufacturer: Crane Composites
8015 Dixon Drive
Florence, KY 41042

Specimen: Duralite High Strength R-Panel, light transmitting panel,
8 oz with woven roving

Support Fastener : #12-14 X 1" self tapping screws with corrosion resistant coating and
1-1/8" dia. stainless steel washer backer with an EPDM gasket

Side Lap Fastener: #6 X 1-1/4" stainless steel grommet with hex head machine screw
and neoprene sleeve with threaded insert

Testing Apparatus

Test Chamber: The test chamber consist of three sections: a top section to create a uniform vacuum, a center section in which the roof assembly is constructed, and a bottom section to create a uniform positive pressure.

Pressure Chamber: The air pressure in the pressure chamber was measured at five points. Each of four points were located 42" from chamber corners at a 45 degree angle, with the fifth tube located 18" from the center of the air inlet opening. The end of each tube was 7" above the chamber floor. The tubes were connected to a manifold that, in turn was connected to a manometer.

Vacuum Chamber Measurement: The air pressure in the vacuum chamber was measured at five points. Each of four points was located 18" from chamber corners at a 45 degree angle and 8" above the chamber floor. The fifth tube located 12" from the center of the exhaust opening and 6" below the opening. The tubes were connected to a manifold that, in turn was connected to a manometer. The pressure in the vacuum chamber was controlled by an automatic damper. The damper door was moved by means of an air motor hooked to an air line and controlled by pressure switches located in the control console. An additional pressure line from the manifold to pressure switches controlled the automatic damper.

Project No. T214-10

Installation

- The substrate was comprised of 8" X 3" X 16 ga zee purlins spaced as shown on the attached drawings. The perimeter was 8" X 2" X 16 ga track attached to the test frame as shown on the attached drawings.
- The roof panels were attached to the zee purlins using #12-14 X 1" self tapping screws spaced as shown on the attached drawings. The panel side laps used #6 X 1-1/4" stainless steel grommet fasteners located @ 10" on centers. The panels were attached to the perimeter of the panel assembly with #12-14 X 1" self tapping screws (9 per panel at panel ends and at 6" on center at longitudinal sides).
- A plastic barrier was located between the panels and the underlying substrate.

Test Procedure

- The test assembly was subjected to positive and negative pressures to form an uplift pressure at the values and time duration per UL 580 as shown in the attached table.
- Vertical movement of the assembly during the tests was recorded.

Project No. T214-10

TEST #1
UL 580 UPLIFT TEST

Test Date: 5/7/10

Max. Support Spacing: 5' oc

Class 30 Deflection Measurements

Phase	Time Duration (min.)	Negative Pressure (psf)	Positive Pressure (psf)	#1 (in)	#2 (in)	#3 (in)	#4 (in)
Initial	0	0	0	0	0	0	0
1	5	16.2	0	1/8	1/8	5/8	13/16
2	5	16.2	13.8	3/16	3/8	1	1-9/16
3	60	8.1 – 27.7*	13.8	1/4	1/2	1-3/8	2-1/16
4	5	24.2	0	3/16	5/16	15/16	1-7/16
5	5	24.2	20.8	1/4	5/8	1-1/2	2-5/16

Class 60 Deflection Measurements

Phase	Time Duration (min.)	Negative Pressure (psf)	Positive Pressure (psf)	#1 (in)	#2 (in)	#3 (in)	#4 (in)
1	5	32.3	0	3/16	3/8	1-1/4	1-15/16
2	5	32.3	27.7	3/8	5/8	1-15/16	2-15/16
3	60	16.2 – 55.4*	27.7	5/8	1	2-1/2	3-15/16

* Oscillation frequency as specified in UL 580.

Results:

Maximum Total Uplift Test Pressure = 83.1 psf

During the Phase 3 of the Class 60 loading sequence, the panel specimen sustained the required loads for a period of 20 min and then the panel cracked at the purlin support location.

Project No. T214-10

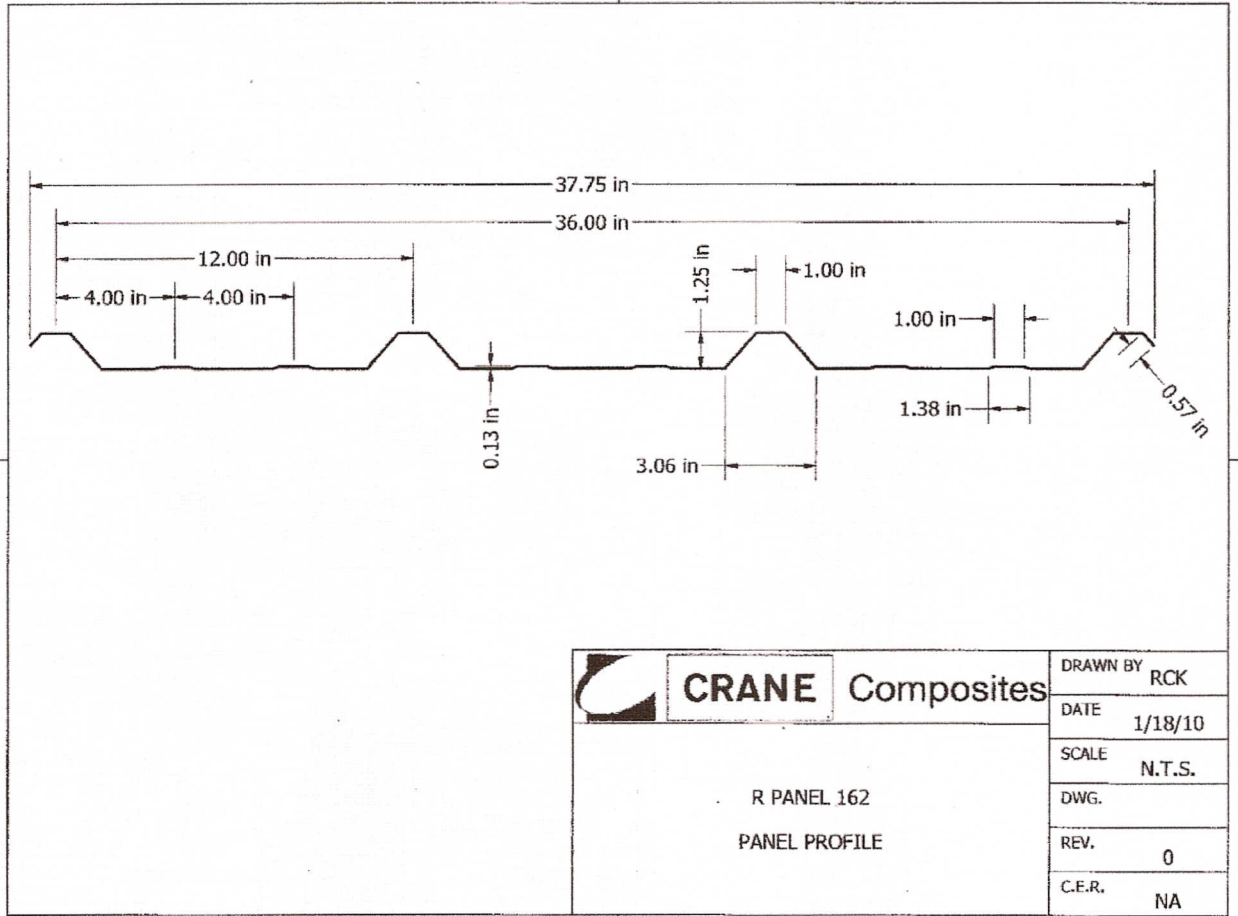

Project No. T214-10

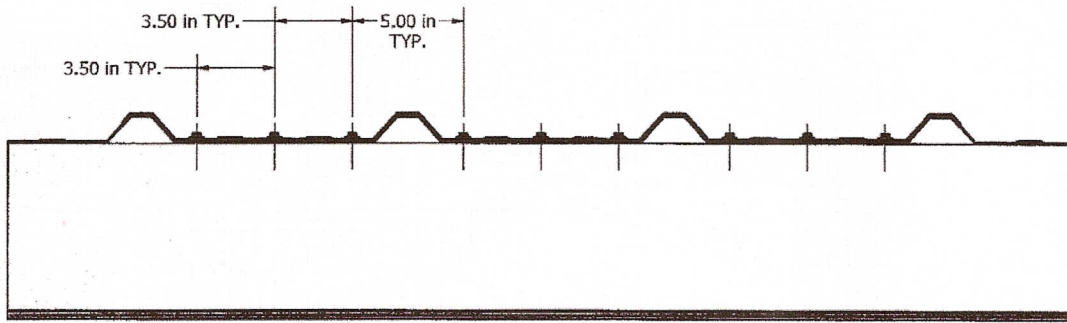

PANEL TO SUPPORT FASTENER DETAIL
(AT ALL PURLIN SUPPORTS AND PANEL ENDS)

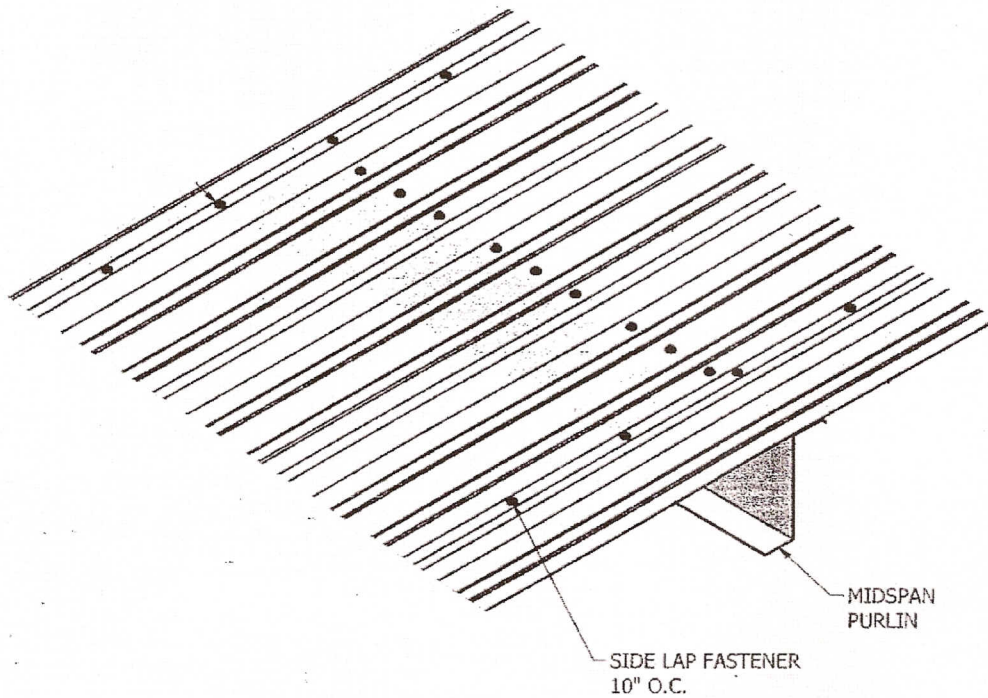

PANEL SIDE LAP DETAIL

Project No. T214-10

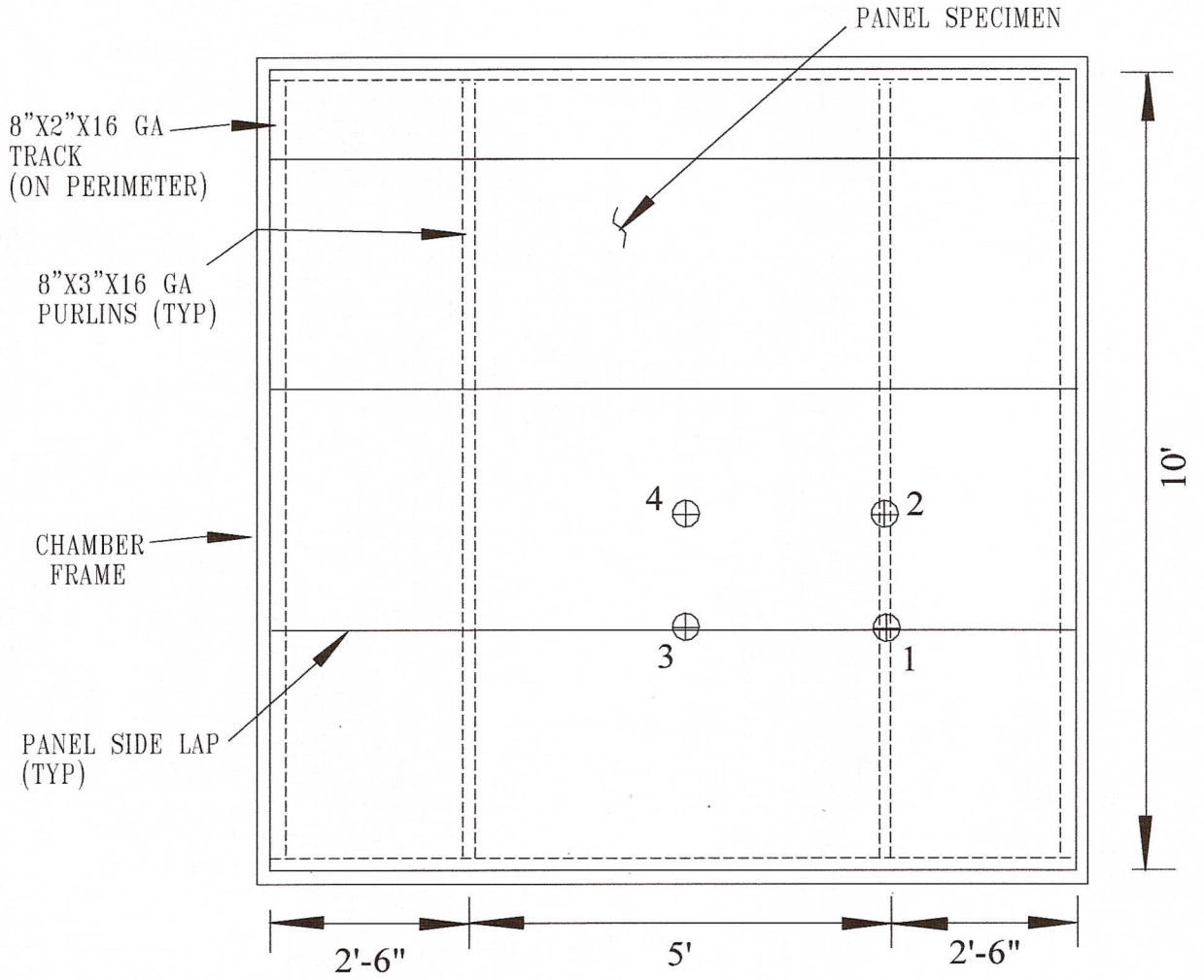

PLAN VIEW

⊕ DEFLECTION POINT